

ASSEMBLY OF THE POSTURE POUCH TO A LAPTOP.

Important: During any transit of the unit, always ensure that the portable computer is suitably supported or carried. Do not rely on the Posture Pouch as the portable computer may slip out if not properly secured or supported.

Self adhesive Velcro pads

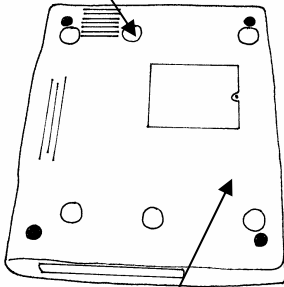

Underside of laptop.

Affix the self adhesive Velcro pads (provided) to the underside of the laptop. The distance between the pads must be the same as the distance between the Velcro strips on the POSTURE POUCH. **DO NOT PLACE PADS ON ANY COOLING VENTS.** Equally position all pads provided if possible, with one pad placed as near to the front and rear edges as possible on each side.

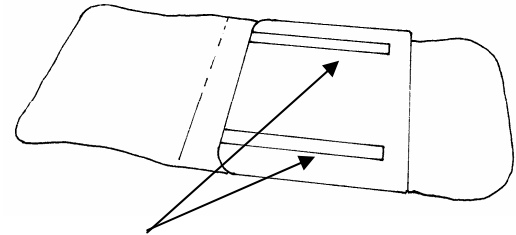

Posture Pouch opened up to expose Velcro strips

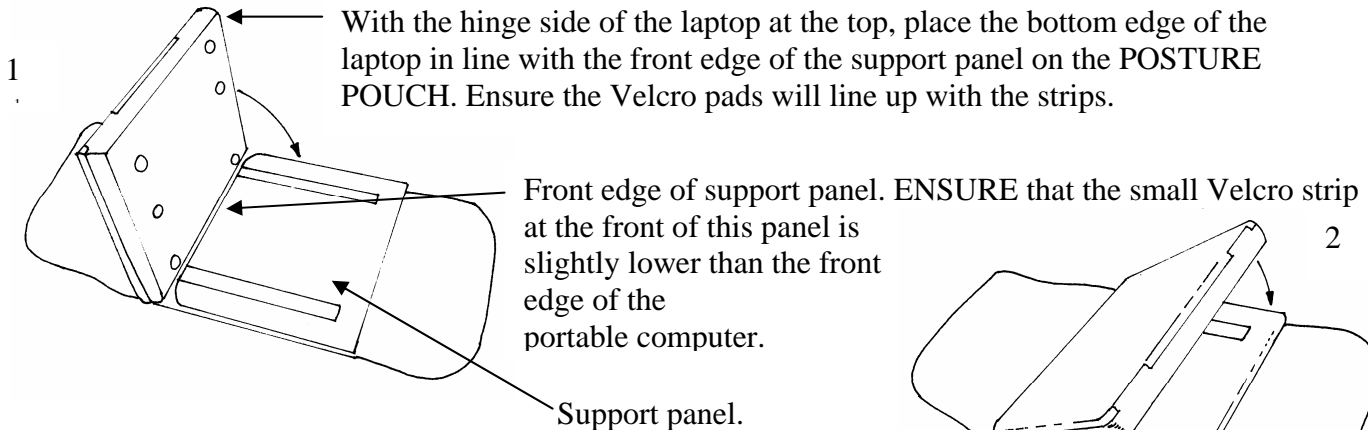

Lower the laptop down to engage the Velcro pads and strips. Allow 24 hours before removing.

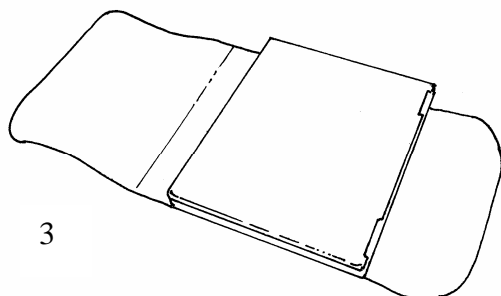
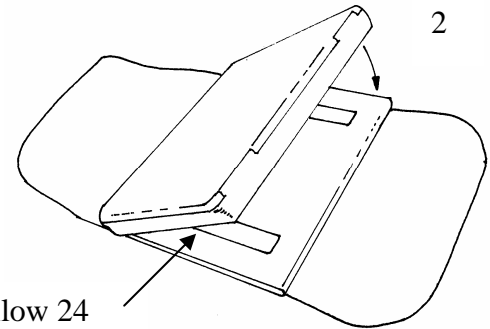

Lightly press the laptop down to engage the Velcro pads and strips. If alignments are satisfactory, allow 24 hours before removing.

Reverse above process to remove laptop.

As with all ergonomic stands, and given that all portable computers are different, it is important to ensure that your unit does not overheat after fitting this accessory.